

NOTES:

1. THIS PLAN AND LONGITUDINAL SECTION HAS BEEN PREPARED USING LEVELS INTERPOLATED FROM LIDAR DATA AND LOCATION OF SERVICES AS PROVIDED BY WINGECARRIBEE SHIRE COUNCIL AND/OR DIAL BEFORE YOU DIG INFORMATION ONLY AND IS FOR PLANNING PURPOSES ONLY.
2. ALL LEVELS AND PIPE GRADES ARE SUBJECT TO CONFIRMATION OF LEVELS BY SURVEY.
3. LOCATION OF THE PROPOSED SEWER PIPE RELATIVE TO EXISTING SERVICES HAS YET TO BE CONFIRMED. ALL DESIGN DETAILS INCLUDING LOCATION, LEVEL AND LENGTH OF PIPE IS SUBJECT TO CONFIRMATION OF LOCATION AND LEVEL OF EXISTING SURFACES AND SERVICES.

NOTES

SW1 All works are to be carried out in accordance with Wingecarribee shire Council Engineering Construction Specifications (current from 1/1/2021)

SW2 Manhole construction is to comply with standard drawing WSC-SEW-005 & as required by Council's Engineer

SW3 All services and assets are to be located by Dial Before You Dig and or investigations on site and located by hand digging, identified, marked and protected by the contractor.

SW4 Council is to be notified 48 hours prior to commencement of works and for inspections.

SW5 Junctions and sidelines are to be left open to allow work as executed inspection to be carried out prior to backfilling.

SW6 All work to be inspected by Council prior to backfilling.

SW7 Sewer junctions to be marked with sewer main marking tape tied from the sewer junction to a hardwood stake of minimum 40mm square X 400mm long at 100mm above ground, the stake to be painted yellow.

SW8 Riser to be fitted to all sewer junctions and terminated approximately 500mm below finished surface level where depth exceeds 1.2m. Refer PWD ST. 503.

SW9 Relevant fees to be paid for Council to undertake any junction cut-ins on existing mains.

PLAN LIST AND ISSUE REGISTER

SHEET NO.	DESCRIPTION	ISSUE
1	REFERENCE PLAN	B
2	PLAN A	B
3	PLANS B & C	B
4	PLAN D	B
5	PLANS E & F	B
6	PLANS G & H	B
7	PLAN I	B
8	SECTION 00 - 318.215	B
9	SECTION 318.215 - 639.156	B
10	SECTION 639.156 - 983.956	B
11	SECTION 983.956 - 1272.856	B
12	SECTION 1272.856 - 1579.807	B
13	SECTION 1579.807 - 1929.690	B
14	SECTION 1929.690 - 2165.737	B

LOCALITY PLAN AND PLAN SHEET REFERENCE PLAN

VER	BY	AMENDMENTS	DATE
A	T.H.	ISSUED FOR INFORMATION	5-11-2022
B	T.H.	PLAN LIST AMENDED	02-02-2023
C			
D			
E			
F			
G			

• THE POSITION OF SERVICES SHOWN ON THIS DRAWING ARE INDICATIVE ONLY AND HAVE BEEN PLOTTED FROM PLANS AND DRAWINGS SUPPLIED BY RELEVANT AUTHORITIES.

• SERVICE AUTHORITY PITS, MANHOLES, POLES, MARKER POSTS, ETC., WHERE SIGHTED AT TIME OF SURVEY, HAVE BEEN LOCATED. THE SURVEY DOES NOT INCLUDE INVESTIGATION OR LOCATION OF UNDERGROUND INFRASTRUCTURE.

• SERVICES INFORMATION SHOWN ON THIS DRAWING HAS BEEN OBTAINED THROUGH A DIAL BEFORE YOU DIG SEARCH AND IS VALID FOR THE PERIOD OF TIME FROM THE DATE OF ISSUE NOMINATED BY THE AUTHORITY.

• PRIOR TO ANY DEMOLITION, EXCAVATION OR CONSTRUCTION ON OR ADJACENT TO THE SITE IT IS THE RESPONSIBILITY OF THE DEVELOPER AND CONTRACTORS TO APPLY FOR AND OBTAIN UP TO DATE PLANS THROUGH A NEW DIAL BEFORE YOU DIG SEARCH AND TO CONTACT ALL THE RELEVANT AUTHORITIES TO ESTABLISH AND CONFIRM THE DETAILED LOCATION AND DEPTH OF ALL UNDERGROUND SERVICES.

CLIENT:  
PRIME MOSS VALE

**BW** Beveridge Williams  
Land Development Consultants  
Registered Surveyors  
Miranda (02) 9524 4073 www.beveridgewilliams.com.au

DETAILS:  
PLAN OF STAGE 2 TRUNK SEWER WORKS  
ASSOCIATED WITH CHELSEA GARDENS  
DEVELOPMENT, YARRAWA ROAD  
MOSS VALE

SCALE ORIGINAL SHEET SIZE  
1:4000 A1  
CAD REFERENCE: lidar  
0 80 160 240  
SCALE ON ORIGINAL DRAWING AT 1:4000

SURVEYOR:	X.X.
DRAWN:	X.X.
CHECKED:	D.S.
SURVEY DATE:	X.X.X
VERTICAL DATUM:	AHD
HORIZONTAL DATUM:	MGA

PROJECT No.	18001S3
DRAWING REF.	REFERENCE PLAN
VERSION	A
SHEET	1 OF 14

NOTES:

1. THIS PLAN AND LONGITUDINAL SECTION HAS BEEN PREPARED USING LEVELS INTERPOLATED FROM LIDAR DATA AND LOCATION OF SERVICES AS PROVIDED BY WINGECARRIBEE SHIRE COUNCIL AND/OR DIAL BEFORE YOU DIG INFORMATION ONLY AND IS FOR PLANNING PURPOSES ONLY.
2. ALL LEVELS AND PIPE GRADES ARE SUBJECT TO CONFIRMATION OF LEVELS BY SURVEY.
3. LOCATION OF THE PROPOSED SEWER PIPE RELATIVE TO EXISTING SERVICES HAS YET TO BE CONFIRMED. ALL DESIGN DETAILS INCLUDING LOCATION, LEVEL AND LENGTH OF PIPE IS SUBJECT TO CONFIRMATION OF LOCATION AND LEVEL OF EXISTING SURFACES AND SERVICES.

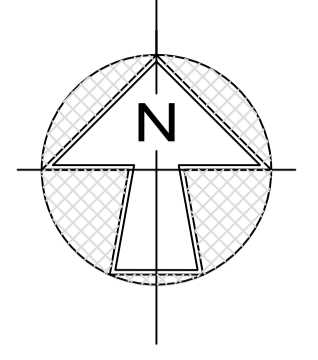

⊗ DENOTES SECTION OF PROPOSED SEWER IS LOCATED WITHIN PRIVATE PROPERTY & IS SUBJECT TO CREATION OF SUITABLE EASEMENT

CONNECT TO MH PROPOSED. REFER TO DRAWING REF: 18001S2 PREPARED BY BEVERIDGE WILLIAMS

COUNCIL LOT 3  
DP 775152

COUNCIL LOT 2  
DP 775152

LOT 1  
DP775152

LEGEND	
	DENOTES EXISTING WATER MAINS
	DENOTES EXISTING STORMWATER PIPES
	DENOTES EXISTING SEWER MAINS
	DENOTES EXISTING ELECTRICAL SERVICES
	DENOTES EXISTING NBN SERVICES
	DENOTES EXISTING GAS SERVICES
	DENOTES EXISTING SURFACE CONTOURS
	DENOTES SEWER MANHOLE LABEL

PLAN B (SHEET 3) ADJOINS

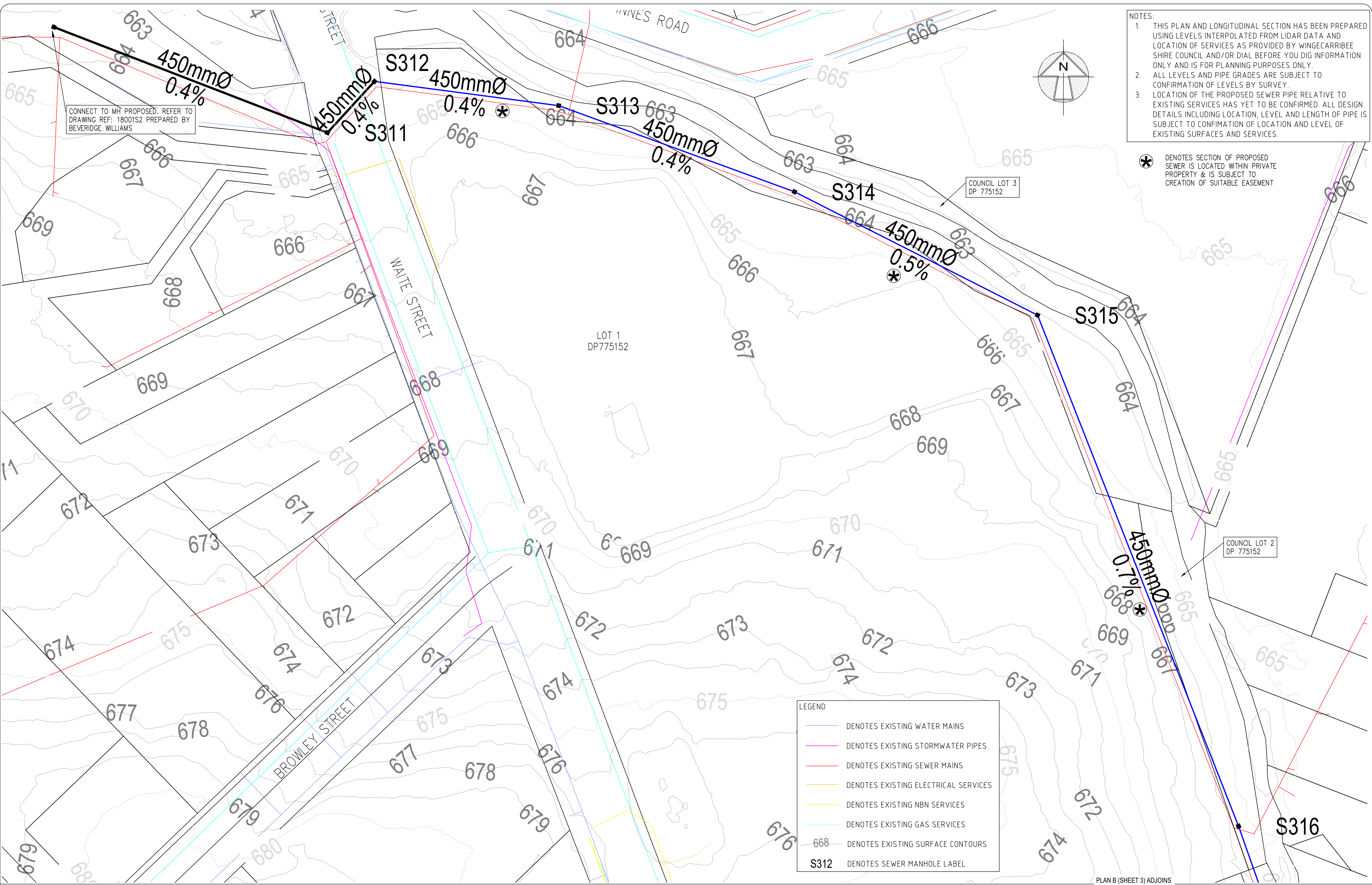

VER	BY	AMENDMENTS	DATE
A	T.H.	ISSUED FOR INFORMATION	5-11-2021
B	T.H.	PIPE SIZES INCREASED TO 450mm	02-02-2022
C			
D			
E			
F			
G			

• THE POSITION OF SERVICES SHOWN ON THIS DRAWING ARE INDICATIVE ONLY AND HAVE BEEN PLOTTED FROM PLANS AND DRAWINGS SUPPLIED BY RELEVANT AUTHORITIES.  
 • SERVICE AUTHORITY PITS, MANHOLES, POLES, MARKER POSTS, ETC., WHERE SIGHTED AT TIME OF SURVEY, HAVE BEEN LOCATED. THE SURVEY DOES NOT INCLUDE INVESTIGATION OR LOCATION OF UNDERGROUND INFRASTRUCTURE.  
 • SERVICES INFORMATION SHOWN ON THIS DRAWING HAS BEEN OBTAINED THROUGH A DIAL BEFORE YOU DIG SEARCH AND IS VALID FOR THE PERIOD OF TIME FROM THE DATE OF ISSUE NOMINATED BY THE AUTHORITY.  
 • PRIOR TO ANY DEMOLITION, EXCAVATION OR CONSTRUCTION ON OR ADJACENT TO THE SITE IT IS THE RESPONSIBILITY OF THE DEVELOPER AND CONTRACTORS TO APPLY FOR AND OBTAIN UP TO DATE PLANS THROUGH A NEW DIAL BEFORE YOU DIG SEARCH AND TO CONTACT ALL THE RELEVANT AUTHORITIES TO ESTABLISH AND CONFIRM THE DETAILED LOCATION AND DEPTH OF ALL UNDERGROUND SERVICES.

CLIENT:  
PRIME MOSS VALE

**BW** Beveridge Williams  
Land Development Consultants  
Registered Surveyors  
Miranda (02) 9524 4073 www.beveridgewilliams.com.au

DETAILS:  
PLAN OF STAGE 2 TRUNK SEWER WORKS  
ASSOCIATED WITH CHELSEA GARDENS  
DEVELOPMENT, YARRAWA ROAD  
MOSS VALE

SCALE	ORIGINAL SHEET SIZE
1:500	A1
CAD REFERENCE: lidar	
SCALE ON ORIGINAL DRAWING AT 1:500	

SURVEYOR:	X.X.
DRAWN:	X.X.
CHECKED:	D.S.
SURVEY DATE:	X.X.X
VERTICAL DATUM:	AHD
HORIZONTAL DATUM:	MGA

PROJECT No.	18001S3
DRAWING REF.	PLAN A
VERSION	B
SHEET	2 OF 14

NOTES:

1. THIS PLAN AND LONGITUDINAL SECTION HAS BEEN PREPARED USING LEVELS INTERPOLATED FROM LIDAR DATA AND LOCATION OF SERVICES AS PROVIDED BY WINGECARRIBEE SHIRE COUNCIL AND/OR DIAL BEFORE YOU DIG INFORMATION ONLY AND IS FOR PLANNING PURPOSES ONLY.
2. ALL LEVELS AND PIPE GRADES ARE SUBJECT TO CONFIRMATION OF LEVELS BY SURVEY.
3. LOCATION OF THE PROPOSED SEWER PIPE RELATIVE TO EXISTING SERVICES HAS YET TO BE CONFIRMED. ALL DESIGN DETAILS INCLUDING LOCATION, LEVEL AND LENGTH OF PIPE IS SUBJECT TO CONFIRMATION OF LOCATION AND LEVEL OF EXISTING SURFACES AND SERVICES.

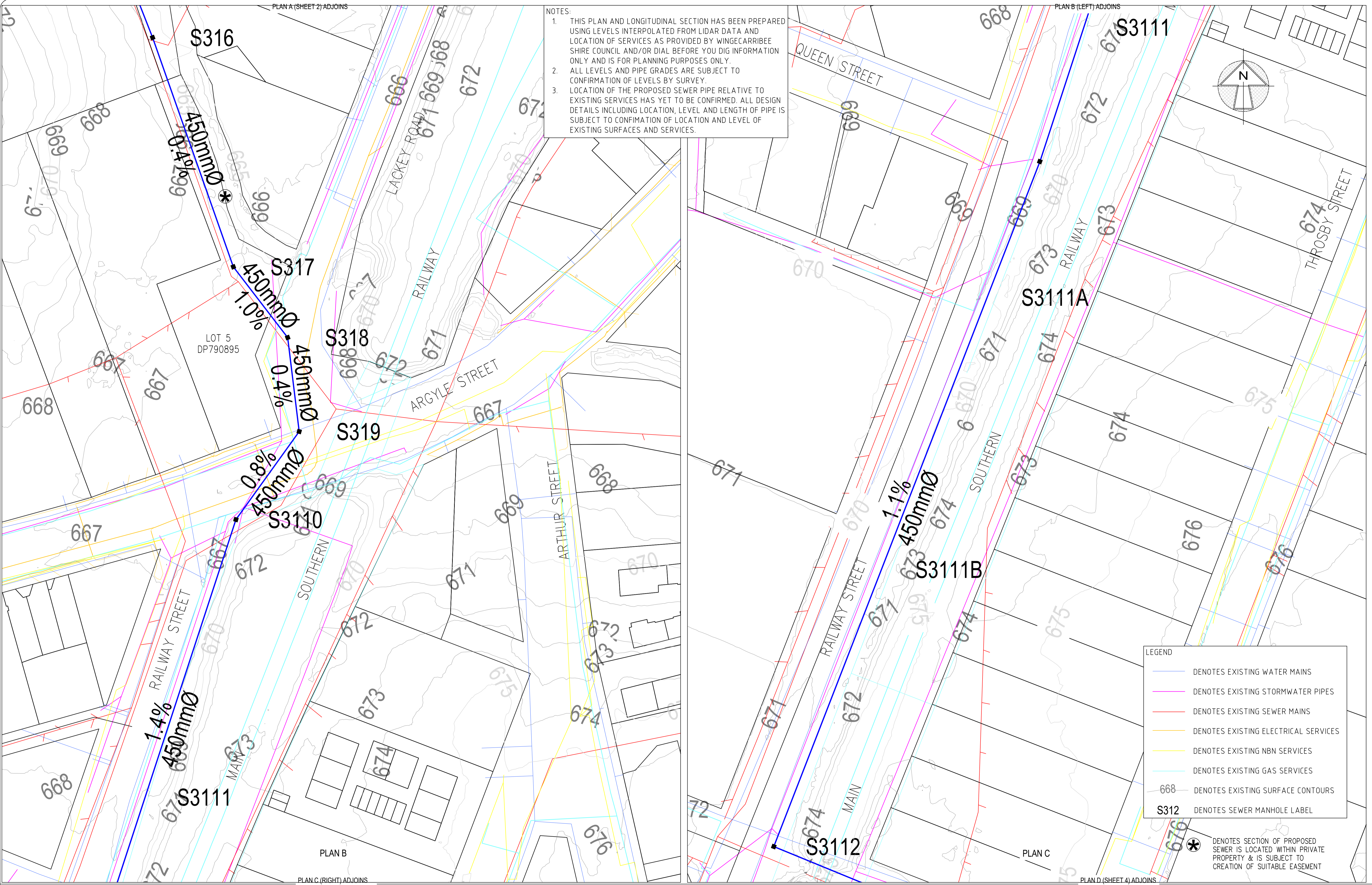
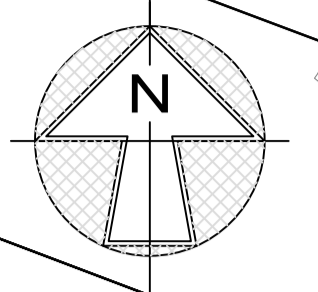

LEGEND

	DENOTES EXISTING WATER MAINS
	DENOTES EXISTING STORMWATER PIPES
	DENOTES EXISTING SEWER MAINS
	DENOTES EXISTING ELECTRICAL SERVICES
	DENOTES EXISTING NBN SERVICES
	DENOTES EXISTING GAS SERVICES
	DENOTES EXISTING SURFACE CONTOURS
	DENOTES SEWER MANHOLE LABEL

DENOTES SECTION OF PROPOSED SEWER IS LOCATED WITHIN PRIVATE PROPERTY & IS SUBJECT TO CREATION OF SUITABLE EASEMENT

VER	BY	AMENDMENTS	DATE
A	T.H.	ISSUED FOR INFORMATION	5-11-2022
B	T.H.	PIPE SIZES INCREASED TO 450mm	02-02-2022
C			
D			
E			
F			
G			

• THE POSITION OF SERVICES SHOWN ON THIS DRAWING ARE INDICATIVE ONLY AND HAVE BEEN PLOTTED FROM PLANS AND DRAWINGS SUPPLIED BY RELEVANT AUTHORITIES.  
 • SERVICE AUTHORITY PITS, MANHOLES, POLES, MARKER POSTS, ETC., WHERE SIGHTED AT TIME OF SURVEY, HAVE BEEN LOCATED. THE SURVEY DOES NOT INCLUDE INVESTIGATION OR LOCATION OF UNDERGROUND INFRASTRUCTURE.  
 • SERVICES INFORMATION SHOWN ON THIS DRAWING HAS BEEN OBTAINED THROUGH A DIAL BEFORE YOU DIG SEARCH AND IS VALID FOR THE PERIOD OF TIME FROM THE DATE OF ISSUE NOMINATED BY THE AUTHORITY.  
 • PRIOR TO ANY DEMOLITION, EXCAVATION OR CONSTRUCTION ON OR ADJACENT TO THE SITE IT IS THE RESPONSIBILITY OF THE DEVELOPER AND CONTRACTORS TO APPLY FOR AND OBTAIN UP TO DATE PLANS THROUGH A NEW DIAL BEFORE YOU DIG SEARCH AND CONTACT ALL THE RELEVANT AUTHORITIES TO ESTABLISH AND CONFIRM THE DETAILED LOCATION AND DEPTH OF ALL UNDERGROUND SERVICES.

CLIENT:  
PRIME MOSS VALE

**Beveridge Williams**  
Land Development Consultants  
Registered Surveyors  
Miranda (02) 9524 4073 www.beveridgewilliams.com.au

DETAILS:  
PLAN OF STAGE 2 TRUNK SEWER WORKS  
ASSOCIATED WITH CHELSEA GARDENS  
DEVELOPMENT, YARRAWA ROAD  
MOSS VALE

ORIGINAL SHEET SIZE A1  
SCALE 1:500  
CAD REFERENCE: lidar  
SCALE ON ORIGINAL DRAWING AT 1:500

SURVEYOR:	X.X.
DRAWN:	X.X.
CHECKED:	D.S.
SURVEY DATE:	X.X.X
VERTICAL DATUM:	AHD
HORIZONTAL DATUM:	MGA

PROJECT No.	18001S3
DRAWING REF.	PLANS B & C
VERSION	B
SHEET	3 OF 14

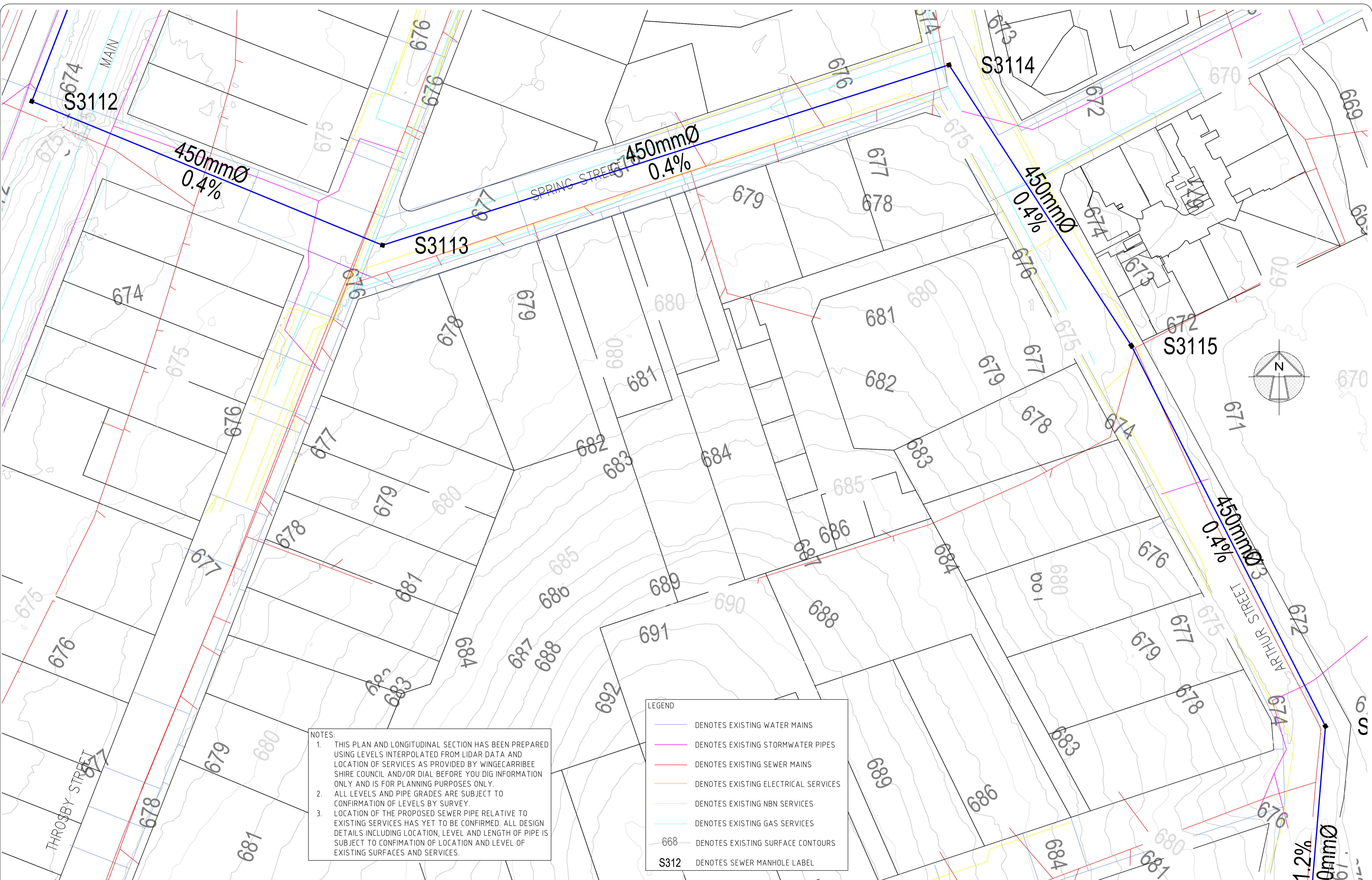

NOTES:

1. THIS PLAN AND LONGITUDINAL SECTION HAS BEEN PREPARED USING LEVELS INTERPOLATED FROM LIDAR DATA AND LOCATION OF SERVICES AS PROVIDED BY WINGECARRIBEE SHIRE COUNCIL AND/OR DIAL BEFORE YOU DIG INFORMATION ONLY AND IS FOR PLANNING PURPOSES ONLY.
2. ALL LEVELS AND PIPE GRADES ARE SUBJECT TO CONFIRMATION OF LEVELS BY SURVEY.
3. LOCATION OF THE PROPOSED SEWER PIPE RELATIVE TO EXISTING SERVICES HAS YET TO BE CONFIRMED. ALL DESIGN DETAILS INCLUDING LOCATION, LEVEL AND LENGTH OF PIPE IS SUBJECT TO CONFIRMATION OF LOCATION AND LEVEL OF EXISTING SURFACES AND SERVICES.

LEGEND	
	DENOTES EXISTING WATER MAINS
	DENOTES EXISTING STORMWATER PIPES
	DENOTES EXISTING SEWER MAINS
	DENOTES EXISTING ELECTRICAL SERVICES
	DENOTES EXISTING NBN SERVICES
	DENOTES EXISTING GAS SERVICES
	DENOTES EXISTING SURFACE CONTOURS
<b>S312</b>	DENOTES SEWER MANHOLE LABEL

VER	BY	AMENDMENTS	DATE
A	T.H.	ISSUED FOR INFORMATION	5-11-2022
B	T.H.	PIPE SIZES INCREASED TO 450mm	02-02-2022
C			
D			
E			
F			
G			

• THE POSITION OF SERVICES SHOWN ON THIS DRAWING ARE INDICATIVE ONLY AND HAVE BEEN PLOTTED FROM PLANS AND DRAWINGS SUPPLIED BY RELEVANT AUTHORITIES.  
 • SERVICE AUTHORITY PITS, MANHOLES, POLES, MARKER POSTS, ETC., WHERE SIGHTED AT TIME OF SURVEY, HAVE BEEN LOCATED. THE SURVEY DOES NOT INCLUDE INVESTIGATION OR LOCATION OF UNDERGROUND INFRASTRUCTURE.  
 • SERVICES INFORMATION SHOWN ON THIS DRAWING HAS BEEN OBTAINED THROUGH A DIAL BEFORE YOU DIG SEARCH AND IS VALID FOR THE PERIOD OF TIME FROM THE DATE OF ISSUE NOMINATED BY THE AUTHORITY.  
 • PRIOR TO ANY DEMOLITION, EXCAVATION OR CONSTRUCTION ON OR ADJACENT TO THE SITE IT IS THE RESPONSIBILITY OF THE DEVELOPER AND CONTRACTORS TO APPLY FOR AND OBTAIN UP TO DATE PLANS THROUGH A NEW DIAL BEFORE YOU DIG SEARCH AND TO CONTACT ALL THE RELEVANT AUTHORITIES TO ESTABLISH AND CONFIRM THE DETAILED LOCATION AND DEPTH OF ALL UNDERGROUND SERVICES.

CLIENT:  
**PRIME MOSS VALE**

**Beveridge Williams**  
 Land Development Consultants  
 Registered Surveyors  
 Miranda (02) 9524 4073    www.beveridgewilliams.com.au

DETAILS:  
**PLAN OF STAGE 2 TRUNK SEWER WORKS  
 ASSOCIATED WITH CHELSEA GARDENS  
 DEVELOPMENT, YARRAWA ROAD  
 MOSS VALE**

SCALE	ORIGINAL SHEET SIZE
1:500	A1
CAD REFERENCE: lidar	
SCALE ON ORIGINAL DRAWING AT 1:500	

SURVEYOR:	X.X.
DRAWN:	X.X.
CHECKED:	D.S.
SURVEY DATE:	X.X.X
VERTICAL DATUM:	AHD
HORIZONTAL DATUM:	MGA

PROJECT No.	18001S3
DRAWING REF.	PLAN D
VERSION	B
SHEET	4 OF 14

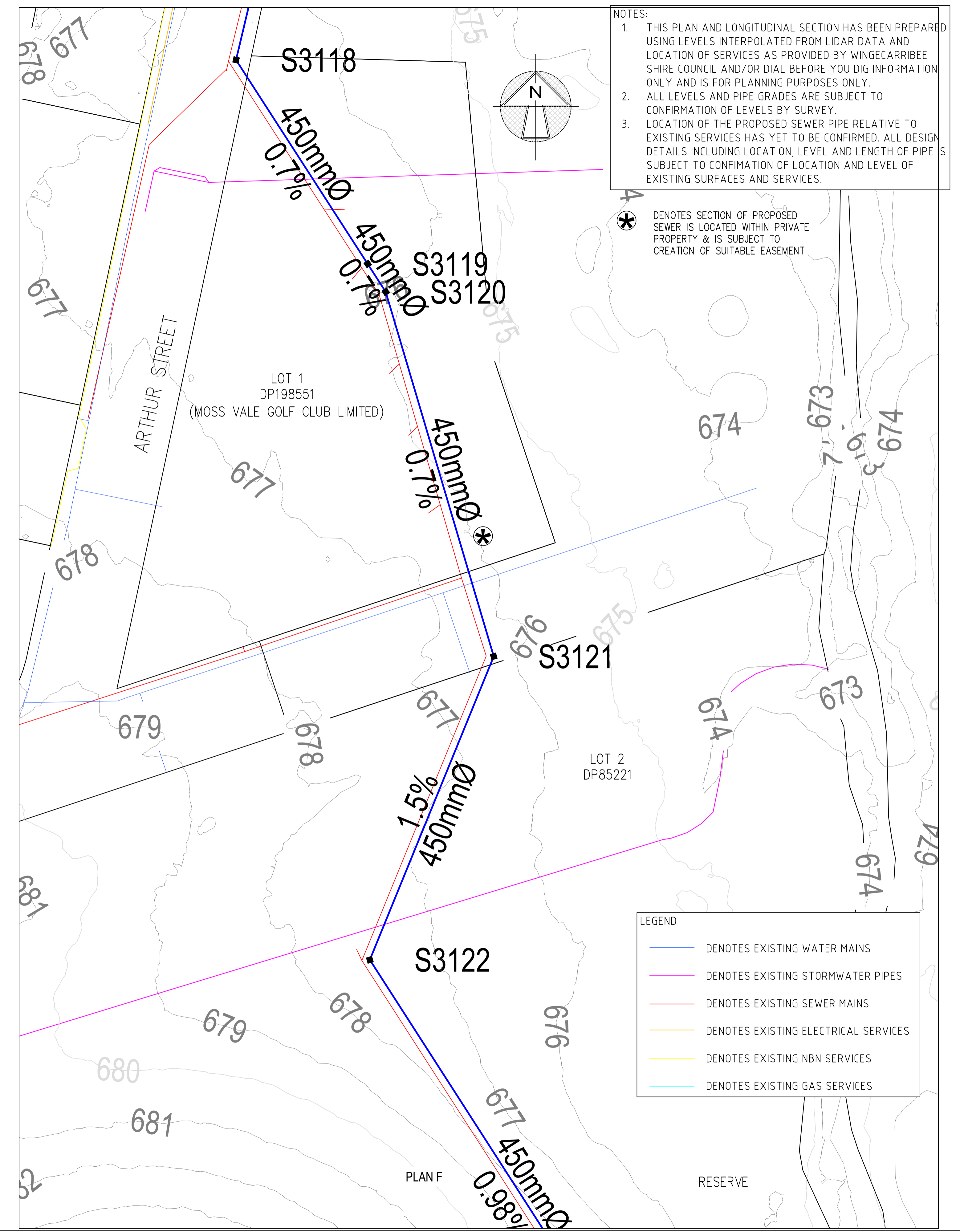
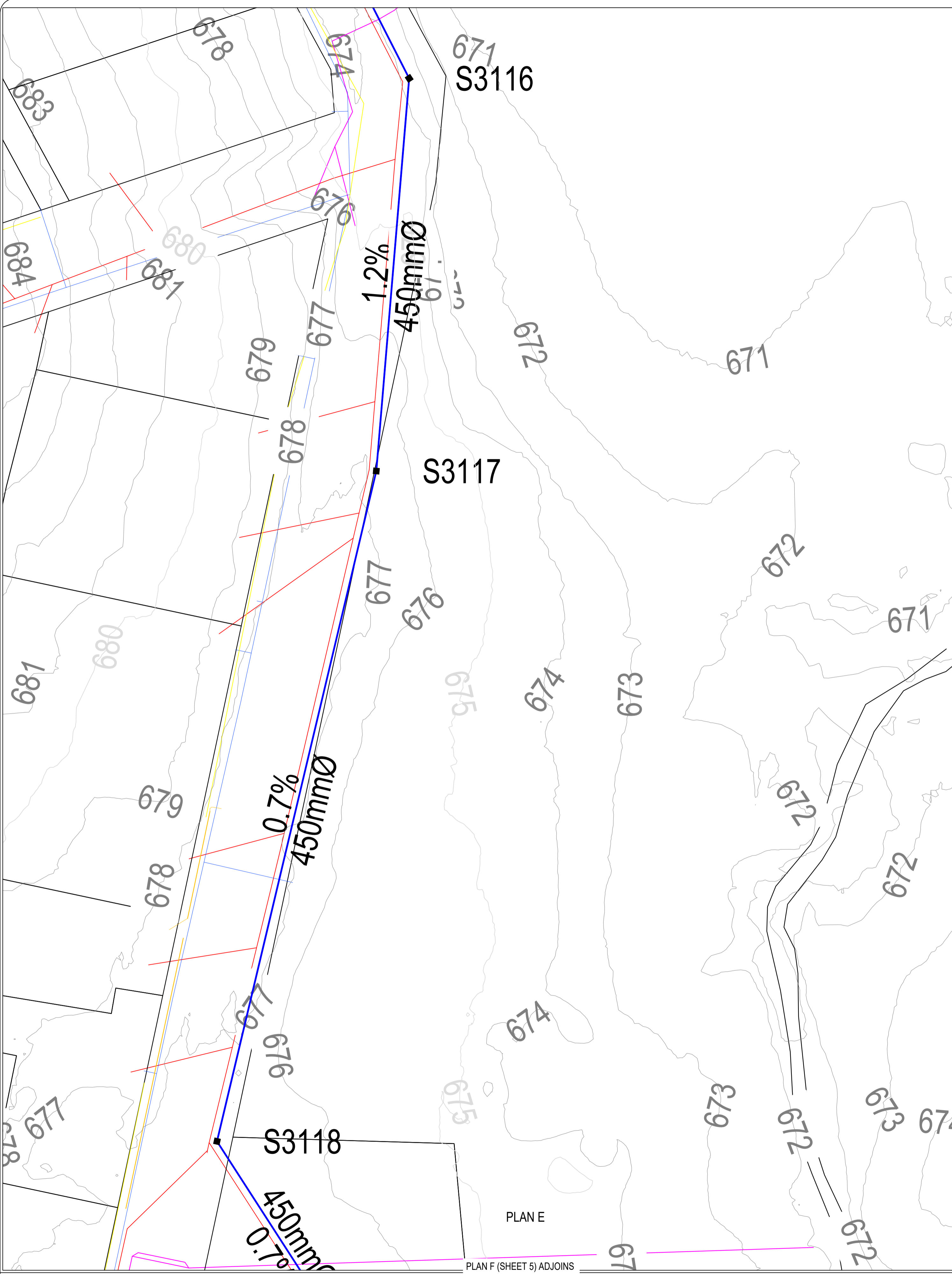

NOTES:

1. THIS PLAN AND LONGITUDINAL SECTION HAS BEEN PREPARED USING LEVELS INTERPOLATED FROM LIDAR DATA AND LOCATION OF SERVICES AS PROVIDED BY WINGECARRIBEE SHIRE COUNCIL AND/OR DIAL BEFORE YOU DIG INFORMATION ONLY AND IS FOR PLANNING PURPOSES ONLY.
2. ALL LEVELS AND PIPE GRADES ARE SUBJECT TO CONFIRMATION OF LEVELS BY SURVEY.
3. LOCATION OF THE PROPOSED SEWER PIPE RELATIVE TO EXISTING SERVICES HAS YET TO BE CONFIRMED. ALL DESIGN DETAILS INCLUDING LOCATION, LEVEL AND LENGTH OF PIPE IS SUBJECT TO CONFIRMATION OF LOCATION AND LEVEL OF EXISTING SURFACES AND SERVICES.

⊗ DENOTES SECTION OF PROPOSED SEWER IS LOCATED WITHIN PRIVATE PROPERTY & IS SUBJECT TO CREATION OF SUITABLE EASEMENT

LEGEND	
	DENOTES EXISTING WATER MAINS
	DENOTES EXISTING STORMWATER PIPES
	DENOTES EXISTING SEWER MAINS
	DENOTES EXISTING ELECTRICAL SERVICES
	DENOTES EXISTING NBN SERVICES
	DENOTES EXISTING GAS SERVICES

VER	BY	AMENDMENTS	DATE
A	T.H.	ISSUED FOR INFORMATION	5-11-2022
B	T.H.	PIPE SIZES INCREASED TO 450mm	02-02-2022
C			
D			
E			
F			
G			

• THE POSITION OF SERVICES SHOWN ON THIS DRAWING ARE INDICATIVE ONLY AND HAVE BEEN PLOTTED FROM PLANS AND DRAWINGS SUPPLIED BY RELEVANT AUTHORITIES.  
 • SERVICE AUTHORITY PITS, MANHOLES, POLES, MARKER POSTS, ETC., WHERE SIGHTED AT TIME OF SURVEY, HAVE BEEN LOCATED. THE SURVEY DOES NOT INCLUDE INVESTIGATION OR LOCATION OF UNDERGROUND INFRASTRUCTURE.  
 • SERVICES INFORMATION SHOWN ON THIS DRAWING HAS BEEN OBTAINED THROUGH A DIAL BEFORE YOU DIG SEARCH AND IS VALID FOR THE PERIOD OF TIME FROM THE DATE OF ISSUE NOMINATED BY THE AUTHORITY.  
 • PRIOR TO ANY DEMOLITION, EXCAVATION OR CONSTRUCTION ON OR ADJACENT TO THE SITE IT IS THE RESPONSIBILITY OF THE DEVELOPER AND CONTRACTORS TO APPLY FOR AND OBTAIN UP TO DATE PLANS THROUGH A NEW DIAL BEFORE YOU DIG SEARCH AND TO CONTACT ALL THE RELEVANT AUTHORITIES TO ESTABLISH AND CONFIRM THE DETAILED LOCATION AND DEPTH OF ALL UNDERGROUND SERVICES.

CLIENT:  
PRIME MOSS VALE

**BW** Beveridge Williams  
Land Development Consultants  
Registered Surveyors  
Miranda (02) 9524 4073 www.beveridgewilliams.com.au

DETAILS:  
PLAN OF STAGE 2 TRUNK SEWER WORKS  
ASSOCIATED WITH CHELSEA GARDENS  
DEVELOPMENT, YARRAWA ROAD  
MOSS VALE

ORIGINAL SCALE 1:500 SHEET SIZE A1  
CAD REFERENCE: lidar  
SCALE ON ORIGINAL DRAWING AT 1:500

SURVEYOR:	X.X.
DRAWN:	X.X.
CHECKED:	D.S.
SURVEY DATE:	X.X.X
VERTICAL DATUM:	AHD
HORIZONTAL DATUM:	MGA

PROJECT No.	18001S3
DRAWING REF.	PLANS E & F
VERSION	B
SHEET	5 OF 14

NOTES:  
 1. THIS PLAN AND LONGITUDINAL SECTION HAS BEEN PREPARED USING LEVELS INTERPOLATED FROM LIDAR DATA AND LOCATION OF SERVICES AS PROVIDED BY WINGECARRIBEE SHIRE COUNCIL AND/OR DIAL BEFORE YOU DIG INFORMATION ONLY AND IS FOR PLANNING PURPOSES ONLY.  
 2. ALL LEVELS AND PIPE GRADES ARE SUBJECT TO CONFIRMATION OF LEVELS BY SURVEY.  
 3. LOCATION OF THE PROPOSED SEWER PIPE RELATIVE TO EXISTING SERVICES HAS YET TO BE CONFIRMED. ALL DESIGN DETAILS INCLUDING LOCATION, LEVEL AND LENGTH OF PIPE IS SUBJECT TO CONFIRMATION OF LOCATION AND LEVEL OF EXISTING SURFACES AND SERVICES.

FUTURE BIORETENTION SYSTEM SUBJECT TO FINAL DESIGN

DN160 RISING MAIN FROM PUMP STATION (SPS1) TO BE INSTALLED IN CONJUNCTION WITH CHELSEA GARDENS STAGE 1 DEVELOPMENT. ALIGNMENT OF RISING MAIN TO BE CONFIRMED

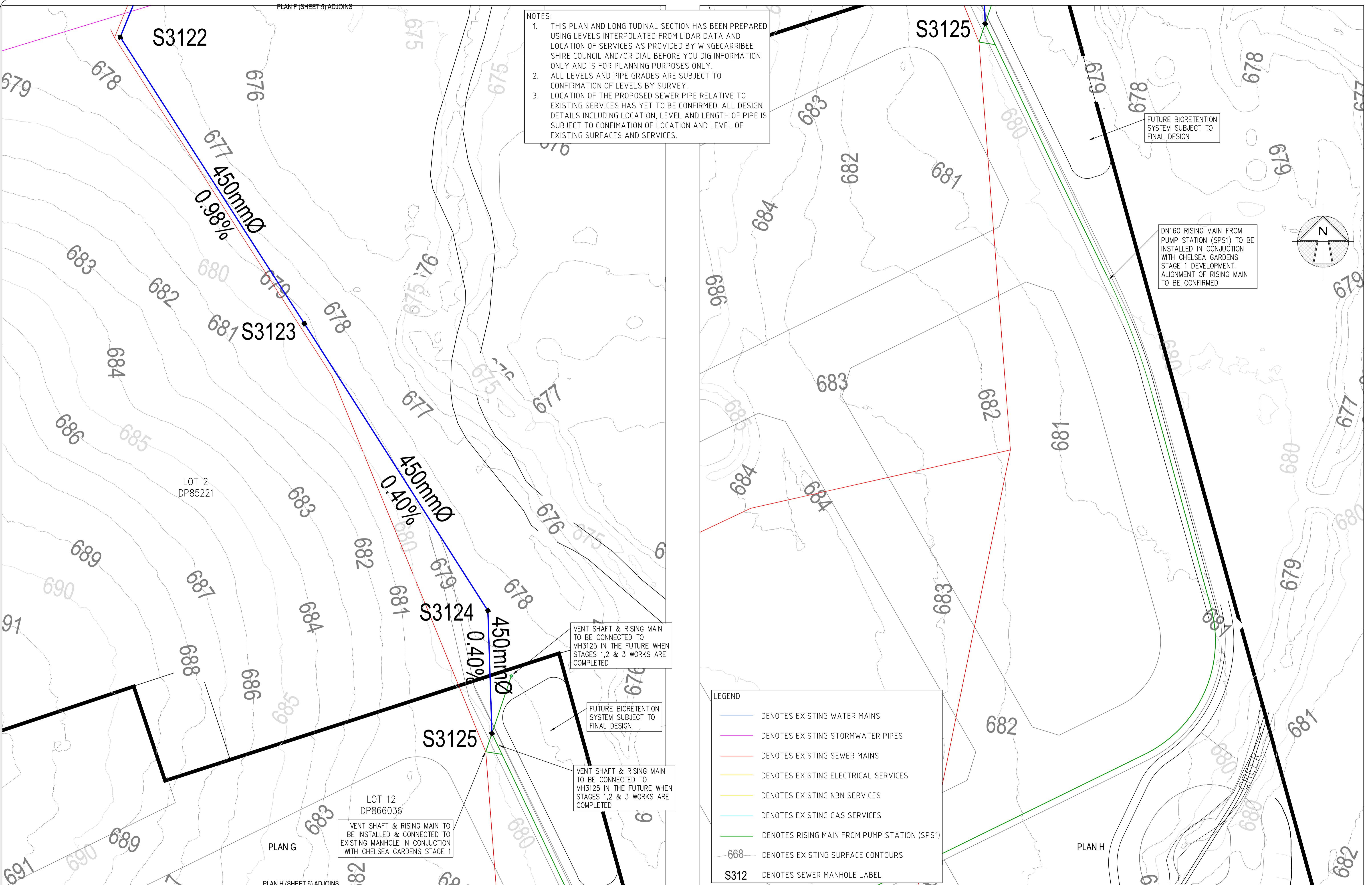
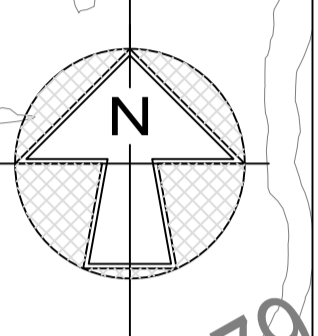

**LEGEND**

- DENOTES EXISTING WATER MAINS
- DENOTES EXISTING STORMWATER PIPES
- DENOTES EXISTING SEWER MAINS
- DENOTES EXISTING ELECTRICAL SERVICES
- DENOTES EXISTING NBN SERVICES
- DENOTES EXISTING GAS SERVICES
- DENOTES RISING MAIN FROM PUMP STATION (SPS1)
- DENOTES EXISTING SURFACE CONTOURS
- S312** DENOTES SEWER MANHOLE LABEL

VER	BY	AMENDMENTS	DATE
A	T.H.	ISSUED FOR INFORMATION	5-11-2021
B	T.H.	PIPE SIZES INCREASED TO 450mm	02-02-2022
C			
D			
E			
F			
G			

• THE POSITION OF SERVICES SHOWN ON THIS DRAWING ARE INDICATIVE ONLY AND HAVE BEEN PLOTTED FROM PLANS AND DRAWINGS SUPPLIED BY RELEVANT AUTHORITIES.  
 • SERVICE AUTHORITY PITS, MANHOLES, POLES, MARKER POSTS, ETC., WHERE SIGHTED AT TIME OF SURVEY, HAVE BEEN LOCATED. THE SURVEY DOES NOT INCLUDE INVESTIGATION OR LOCATION OF UNDERGROUND INFRASTRUCTURE.  
 • SERVICES INFORMATION SHOWN ON THIS DRAWING HAS BEEN OBTAINED THROUGH A DIAL BEFORE YOU DIG SEARCH AND IS VALID FOR THE PERIOD OF TIME FROM THE DATE OF ISSUE NOMINATED BY THE AUTHORITY.  
 • PRIOR TO ANY DEMOLITION, EXCAVATION OR CONSTRUCTION ON OR ADJACENT TO THE SITE IT IS THE RESPONSIBILITY OF THE DEVELOPER AND CONTRACTORS TO APPLY FOR AND OBTAIN UP TO DATE PLANS THROUGH A NEW DIAL BEFORE YOU DIG SEARCH AND TO CONTACT ALL THE RELEVANT AUTHORITIES TO ESTABLISH AND CONFIRM THE DETAILED LOCATION AND DEPTH OF ALL UNDERGROUND SERVICES.

CLIENT:  
**PRIME MOSS VALE**

**BW**  
**Beveridge Williams**  
 Land Development Consultants  
 Registered Surveyors  
 Mirandah (02) 9524 4073 www.beveridgewilliams.com.au

DETAILS:  
**PLAN OF STAGE 2 TRUNK SEWER WORKS**  
 ASSOCIATED WITH CHELSEA GARDENS  
 DEVELOPMENT, YARRAWA ROAD  
 MOSS VALE

ORIGINAL SHEET SIZE  
 SCALE 1:500  
 A1  
 CAD REFERENCE: lidar  
  
 SCALE ON ORIGINAL DRAWING AT 1:500

SURVEYOR:	X.X.
DRAWN:	X.X.
CHECKED:	D.S.
SURVEY DATE:	X.X.X
VERTICAL DATUM:	AHD
HORIZONTAL DATUM:	MGA

PROJECT No.	18001S3
DRAWING REF.	PLANS G & H
VERSION	B
SHEET	6 OF 14

NOTES:

1. THIS PLAN AND LONGITUDINAL SECTION HAS BEEN PREPARED USING LEVELS INTERPOLATED FROM LIDAR DATA AND LOCATION OF SERVICES AS PROVIDED BY WINGECARRIBEE SHIRE COUNCIL AND/OR DIAL BEFORE YOU DIG INFORMATION ONLY AND IS FOR PLANNING PURPOSES ONLY.
2. ALL LEVELS AND PIPE GRADES ARE SUBJECT TO CONFIRMATION OF LEVELS BY SURVEY.
3. LOCATION OF THE PROPOSED SEWER PIPE RELATIVE TO EXISTING SERVICES HAS YET TO BE CONFIRMED. ALL DESIGN DETAILS INCLUDING LOCATION, LEVEL AND LENGTH OF PIPE IS SUBJECT TO CONFIRMATION OF LOCATION AND LEVEL OF EXISTING SURFACES AND SERVICES.

LEGEND

- DENOTES EXISTING WATER MAINS
- DENOTES EXISTING STORMWATER PIPES
- DENOTES EXISTING SEWER MAINS
- DENOTES EXISTING ELECTRICAL SERVICES
- DENOTES EXISTING NBN SERVICES
- DENOTES EXISTING GAS SERVICES
- DENOTES RISING MAIN FROM PUMP STATION (SPS1)
- 688 DENOTES EXISTING SURFACE CONTOURS
- S312 DENOTES SEWER MANHOLE LABEL

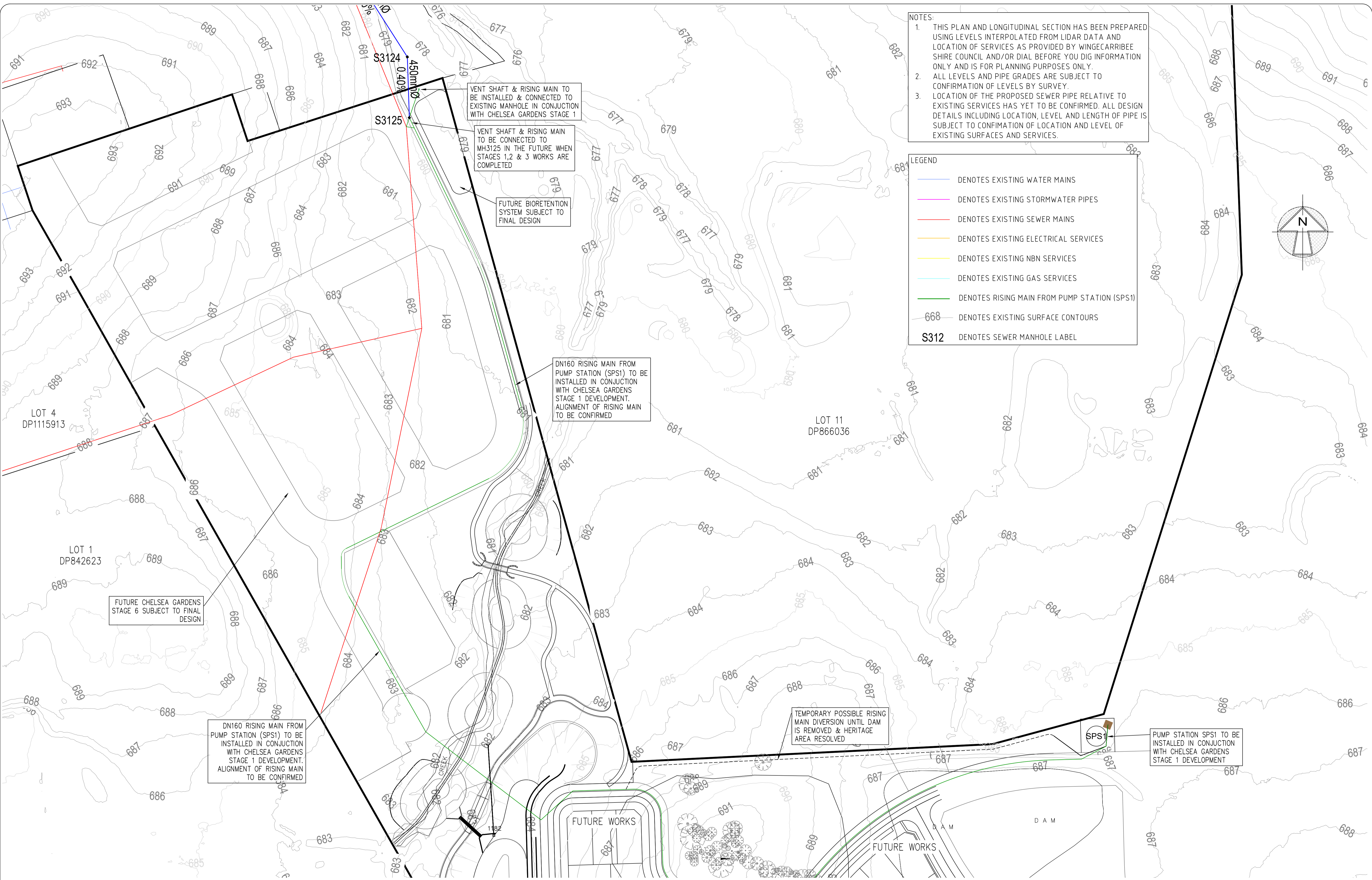
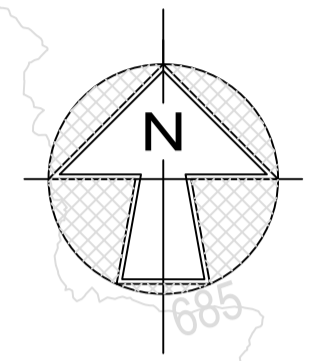

VENT SHAFT & RISING MAIN TO BE INSTALLED & CONNECTED TO EXISTING MANHOLE IN CONJUNCTION WITH CHELSEA GARDENS STAGE 1

VENT SHAFT & RISING MAIN TO BE CONNECTED TO MH3125 IN THE FUTURE WHEN STAGES 1, 2 & 3 WORKS ARE COMPLETED

FUTURE BIORETENTION SYSTEM SUBJECT TO FINAL DESIGN

DN160 RISING MAIN FROM PUMP STATION (SPS1) TO BE INSTALLED IN CONJUNCTION WITH CHELSEA GARDENS STAGE 1 DEVELOPMENT. ALIGNMENT OF RISING MAIN TO BE CONFIRMED

FUTURE CHELSEA GARDENS STAGE 6 SUBJECT TO FINAL DESIGN

DN160 RISING MAIN FROM PUMP STATION (SPS1) TO BE INSTALLED IN CONJUNCTION WITH CHELSEA GARDENS STAGE 1 DEVELOPMENT. ALIGNMENT OF RISING MAIN TO BE CONFIRMED

TEMPORARY POSSIBLE RISING MAIN DIVERSION UNTIL DAM IS REMOVED & HERITAGE AREA RESOLVED

PUMP STATION SPS1 TO BE INSTALLED IN CONJUNCTION WITH CHELSEA GARDENS STAGE 1 DEVELOPMENT

VER	BY	AMENDMENTS	DATE
A	T.H.	ISSUED FOR INFORMATION	5-11-2021
B	T.H.	PIPE SIZES INCREASED TO 450mm	02-02-2022
C			
D			
E			
F			
G			

• THE POSITION OF SERVICES SHOWN ON THIS DRAWING ARE INDICATIVE ONLY AND HAVE BEEN PLOTTED FROM PLANS AND DRAWINGS SUPPLIED BY RELEVANT AUTHORITIES.  
 • SERVICE AUTHORITY PITS, MANHOLES, POLES, MARKER POSTS, ETC., WHERE SIGHTED AT TIME OF SURVEY, HAVE BEEN LOCATED. THE SURVEY DOES NOT INCLUDE INVESTIGATION OR LOCATION OF UNDERGROUND INFRASTRUCTURE.  
 • SERVICES INFORMATION SHOWN ON THIS DRAWING HAS BEEN OBTAINED THROUGH A DIAL BEFORE YOU DIG SEARCH AND IS VALID FOR THE PERIOD OF TIME FROM THE DATE OF ISSUE NOMINATED BY THE AUTHORITY.  
 • PRIOR TO ANY DEMOLITION, EXCAVATION OR CONSTRUCTION ON OR ADJACENT TO THE SITE IT IS THE RESPONSIBILITY OF THE DEVELOPER AND CONTRACTORS TO APPLY FOR AND OBTAIN UP-TO-DATE PLANS THROUGH A NEW DIAL BEFORE YOU DIG SEARCH AND TO CONTACT ALL THE RELEVANT AUTHORITIES TO ESTABLISH AND CONFIRM THE DETAILED LOCATION AND DEPTH OF ALL UNDERGROUND SERVICES.

CLIENT:  
PRIME MOSS VALE

**BW** Beveridge Williams  
Land Development Consultants  
Registered Surveyors  
Miranda (02) 9524 4073  
www.beveridgewilliams.com.au

DETAILS:  
PLAN OF STAGE 2 TRUNK SEWER WORKS  
ASSOCIATED WITH CHELSEA GARDENS  
DEVELOPMENT, YARRAWA ROAD  
MOSS VALE

SCALE ORIGINAL SHEET SIZE 1:1000 A1  
CAD REFERENCE: lidar  
SCALE ON ORIGINAL DRAWING AT 1:1000

SURVEYOR:	X.X.
DRAWN:	X.X.
CHECKED:	D.S.
SURVEY DATE:	X.X.X
VERTICAL DATUM:	AHD
HORIZONTAL DATUM:	MGA

PROJECT No.	18001S3
DRAWING REF.	PLAN I
VERSION	B
SHEET	7 OF 14

S311

S311

S312

S313

S314

S315

NOTES:

1. THIS PLAN AND LONGITUDINAL SECTION HAS BEEN PREPARED USING LEVELS INTERPOLATED FROM LIDAR DATA AND LOCATION OF SERVICES AS PROVIDED BY WINGECARRIBEE SHIRE COUNCIL AND/OR DIAL BEFORE YOU DIG INFORMATION ONLY AND IS FOR PLANNING PURPOSES ONLY.
2. ALL LEVELS AND PIPE GRADES ARE SUBJECT TO CONFIRMATION OF LEVELS BY SURVEY.
3. LOCATION OF THE PROPOSED SEWER PIPE RELATIVE TO EXISTING SERVICES HAS YET TO BE CONFIRMED. ALL DESIGN DETAILS INCLUDING LOCATION, LEVEL AND LENGTH OF PIPE IS SUBJECT TO CONFIRMATION OF LOCATION AND LEVEL OF EXISTING SURFACES AND SERVICES.

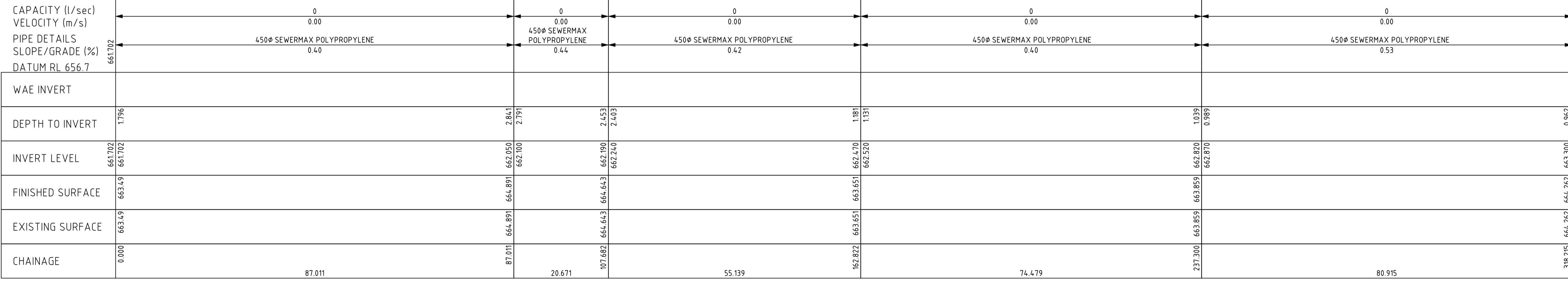

DRAINAGE LONGITUDINAL SECTION FOR LINE 1  
 SCALES: HORIZONTAL 1:500 VERTICAL 1:100

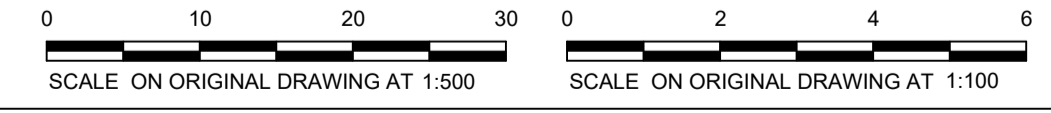

VER	BY	AMENDMENTS	DATE
A	T.H.	ISSUED FOR INFORMATION	5-11-2021
B	T.H.	PIPE SIZES INCREASED TO 450mm	02-02-2022
C			
D			
E			
F			
G			

• THE POSITION OF SERVICES SHOWN ON THIS DRAWING ARE INDICATIVE ONLY AND HAVE BEEN PLOTTED FROM PLANS AND DRAWINGS SUPPLIED BY RELEVANT AUTHORITIES.  
 • SERVICE AUTHORITY FITS, MANHOLES, POLES, MARKER POSTS, ETC., WHERE SIGHTED AT TIME OF SURVEY, HAVE BEEN LOCATED. THE SURVEY DOES NOT INCLUDE INVESTIGATION OR LOCATION OF UNDERGROUND INFRASTRUCTURE.  
 • SERVICES INFORMATION SHOWN ON THIS DRAWING HAS BEEN OBTAINED THROUGH A DIAL BEFORE YOU DIG SEARCH AND IS VALID FOR THE PERIOD OF TIME FROM THE DATE OF ISSUE NOMINATED BY THE AUTHORITY.  
 • PRIOR TO ANY DEMOLITION, EXCAVATION OR CONSTRUCTION ON OR ADJACENT TO THE SITE IT IS THE RESPONSIBILITY OF THE DEVELOPER AND CONTRACTORS TO APPLY FOR AND OBTAIN UP TO DATE PLANS THROUGH A NEW DIAL BEFORE YOU DIG SEARCH AND TO CONTACT ALL THE RELEVANT AUTHORITIES TO ESTABLISH AND CONFIRM THE DETAILED LOCATION AND DEPTH OF ALL UNDERGROUND SERVICES.



CLIENT:  
 PRIME MOSS VALE

**BW** Beveridge Williams  
 Land Development Consultants  
 Registered Surveyors  
 www.beveridgewilliams.com.au

DETAILS:  
 PLAN OF STAGE 2 TRUNK SEWER WORKS  
 ASSOCIATED WITH CHELSEA GARDENS  
 DEVELOPMENT, YARRAWA ROAD  
 MOSS VALE

ORIGINAL SHEET SIZE A1  
 SCALE 1:500  
 CAD REFERENCE: lidar

SURVEYOR: X.X.  
 DRAWN: X.X.  
 CHECKED: D.S.  
 SURVEY DATE: X.X.X  
 VERTICAL DATUM: AHD  
 HORIZONTAL DATUM: MGA

PROJECT No. 18001S3  
 DRAWING REF. SECTION 00 - 318.215  
 VERSION B  
 SHEET 8 OF 14



S315

S315A

S316

S317

S318

S319

S3110

NOTES:

1. THIS PLAN AND LONGITUDINAL SECTION HAS BEEN PREPARED USING LEVELS INTERPOLATED FROM LIDAR DATA AND LOCATION OF SERVICES AS PROVIDED BY WINGECARRIBEE SHIRE COUNCIL AND/OR DIAL BEFORE YOU DIG INFORMATION ONLY AND IS FOR PLANNING PURPOSES ONLY.
2. ALL LEVELS AND PIPE GRADES ARE SUBJECT TO CONFIRMATION OF LEVELS BY SURVEY.
3. LOCATION OF THE PROPOSED SEWER PIPE RELATIVE TO EXISTING SERVICES HAS YET TO BE CONFIRMED. ALL DESIGN DETAILS INCLUDING LOCATION, LEVEL AND LENGTH OF PIPE IS SUBJECT TO CONFIRMATION OF LOCATION AND LEVEL OF EXISTING SURFACES AND SERVICES.

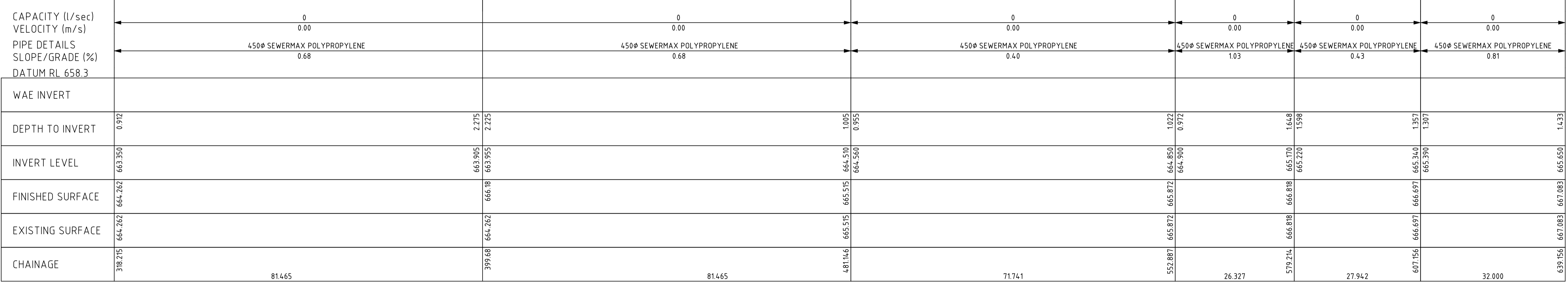

DRAINAGE LONGITUDINAL SECTION FOR LINE 1  
 SCALES: HORIZONTAL 1:500 VERTICAL 1:100

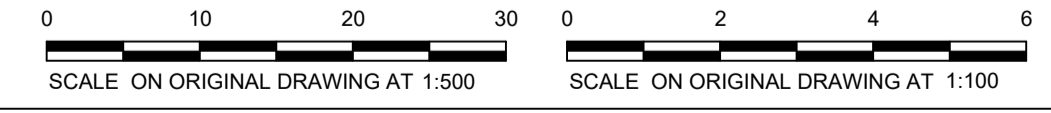

VER	BY	AMENDMENTS	DATE
A	T.H.	ISSUED FOR INFORMATION	5-11-2021
B	T.H.	PIPE SIZES INCREASED TO 450mm	02-02-2022
C			
D			
E			
F			
G			

• THE POSITION OF SERVICES SHOWN ON THIS DRAWING ARE INDICATIVE ONLY AND HAVE BEEN PLOTTED FROM PLANS AND DRAWINGS SUPPLIED BY RELEVANT AUTHORITIES.  
 • SERVICE AUTHORITY FITS, MANHOLES, POLES, MARKER POSTS, ETC., WHERE SIGHTED AT TIME OF SURVEY, HAVE BEEN LOCATED. THE SURVEY DOES NOT INCLUDE INVESTIGATION OR LOCATION OF UNDERGROUND INFRASTRUCTURE.  
 • SERVICES INFORMATION SHOWN ON THIS DRAWING HAS BEEN OBTAINED THROUGH A DIAL BEFORE YOU DIG SEARCH AND IS VALID FOR THE PERIOD OF TIME FROM THE DATE OF ISSUE NOMINATED BY THE AUTHORITY.  
 • PRIOR TO ANY DEMOLITION, EXCAVATION OR CONSTRUCTION ON OR ADJACENT TO THE SITE IT IS THE RESPONSIBILITY OF THE DEVELOPER AND CONTRACTORS TO APPLY FOR AND OBTAIN UP TO DATE PLANS THROUGH A NEW DIAL BEFORE YOU DIG SEARCH AND TO CONTACT ALL THE RELEVANT AUTHORITIES TO ESTABLISH AND CONFIRM THE DETAILED LOCATION AND DEPTH OF ALL UNDERGROUND SERVICES.

CLIENT:  
**PRIME MOSS VALE**

**Beveridge Williams**  
 Land Development Consultants  
 Registered Surveyors  
 www.beveridgewilliams.com.au

DETAILS:  
**PLAN OF STAGE 2 TRUNK SEWER WORKS ASSOCIATED WITH CHELSEA GARDENS DEVELOPMENT, YARRAWA ROAD MOSS VALE**

SCALE ORIGINAL SHEET SIZE  
 1:500 A1  
 CAD REFERENCE: lidar

SURVEYOR: X.X.  
 DRAWN: X.X.  
 CHECKED: D.S.  
 SURVEY DATE: X.X.X  
 VERTICAL DATUM: AHD  
 HORIZONTAL DATUM: MGA

PROJECT No.  
**18001S3**  
 DRAWING REF.  
**SECTION 318.215-639.156**  
 VERSION **B**  
 SHEET **9** OF **14**

S3110

S3111

S3111A

S3111B

S3112

NOTES:

1. THIS PLAN AND LONGITUDINAL SECTION HAS BEEN PREPARED USING LEVELS INTERPOLATED FROM LIDAR DATA AND LOCATION OF SERVICES AS PROVIDED BY WINGECARRIBEE SHIRE COUNCIL AND/OR DIAL BEFORE YOU DIG INFORMATION ONLY AND IS FOR PLANNING PURPOSES ONLY.
2. ALL LEVELS AND PIPE GRADES ARE SUBJECT TO CONFIRMATION OF LEVELS BY SURVEY.
3. LOCATION OF THE PROPOSED SEWER PIPE RELATIVE TO EXISTING SERVICES HAS YET TO BE CONFIRMED. ALL DESIGN DETAILS INCLUDING LOCATION, LEVEL AND LENGTH OF PIPE IS SUBJECT TO CONFIRMATION OF LOCATION AND LEVEL OF EXISTING SURFACES AND SERVICES.

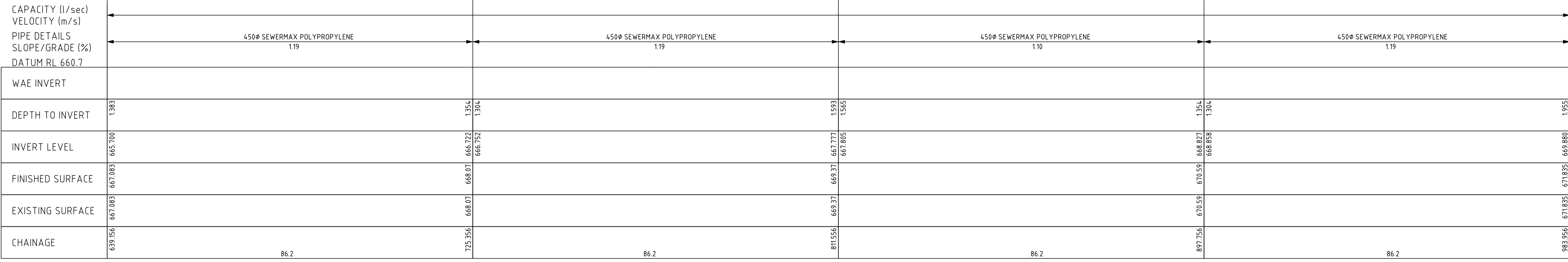

DRAINAGE LONGITUDINAL SECTION FOR LINE 1  
 SCALES: HORIZONTAL 1:500 VERTICAL 1:100

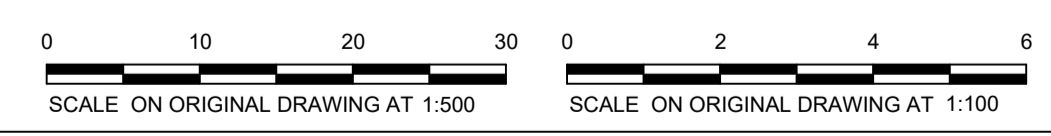

VER	BY	AMENDMENTS	DATE
A	T.H.	ISSUED FOR INFORMATION	5-11-2021
B	T.H.	PIPE SIZES INCREASED TO 450mm	02-02-2022
C			
D			
E			
F			
G			

• THE POSITION OF SERVICES SHOWN ON THIS DRAWING ARE INDICATIVE ONLY AND HAVE BEEN PLOTTED FROM PLANS AND DRAWINGS SUPPLIED BY RELEVANT AUTHORITIES.  
 • SERVICE AUTHORITY FITS, MANHOLES, POLES, MARKER POSTS, ETC., WHERE SIGHTED AT TIME OF SURVEY, HAVE BEEN LOCATED. THE SURVEY DOES NOT INCLUDE INVESTIGATION OR LOCATION OF UNDERGROUND INFRASTRUCTURE.  
 • SERVICES INFORMATION SHOWN ON THIS DRAWING HAS BEEN OBTAINED THROUGH A DIAL BEFORE YOU DIG SEARCH AND IS VALID FOR THE PERIOD OF TIME FROM THE DATE OF ISSUE NOMINATED BY THE AUTHORITY.  
 • PRIOR TO ANY DEMOLITION, EXCAVATION OR CONSTRUCTION ON OR ADJACENT TO THE SITE IT IS THE RESPONSIBILITY OF THE DEVELOPER AND CONTRACTORS TO APPLY FOR AND OBTAIN UP TO DATE PLANS THROUGH A NEW DIAL BEFORE YOU DIG SEARCH AND TO CONTACT ALL THE RELEVANT AUTHORITIES TO ESTABLISH AND CONFIRM THE DETAILED LOCATION AND DEPTH OF ALL UNDERGROUND SERVICES.

[www.dialbeforeyoudig.com.au](http://www.dialbeforeyoudig.com.au)  
**DIAL 1100**  
 BEFORE YOU DIG

CLIENT:  
**PRIME MOSS VALE**

**BW**  
**Beveridge Williams**  
 Land Development Consultants  
 Registered Surveyors  
[www.beveridgewilliams.com.au](http://www.beveridgewilliams.com.au)

DETAILS:  
**PLAN OF STAGE 2 TRUNK SEWER WORKS ASSOCIATED WITH CHELSEA GARDENS DEVELOPMENT, YARRAWA ROAD MOSS VALE**

SCALE ORIGINAL SHEET SIZE  
 1:500 A1  
 CAD REFERENCE: lidar

SURVEYOR: X.X.  
 DRAWN: X.X.  
 CHECKED: D.S.  
 SURVEY DATE: X.X.X  
 VERTICAL DATUM: AHD  
 HORIZONTAL DATUM: MGA

PROJECT No.  
**18001S3**  
 DRAWING REF.  
**SECTION 639.156-983.956**  
 VERSION **B**  
 SHEET 10 OF 14

53112

53113

53114

- NOTES:
1. THIS PLAN AND LONGITUDINAL SECTION HAS BEEN PREPARED USING LEVELS INTERPOLATED FROM LIDAR DATA AND LOCATION OF SERVICES AS PROVIDED BY WINGECARRIBEE SHIRE COUNCIL AND/OR DIAL BEFORE YOU DIG INFORMATION ONLY AND IS FOR PLANNING PURPOSES ONLY.
  2. ALL LEVELS AND PIPE GRADES ARE SUBJECT TO CONFIRMATION OF LEVELS BY SURVEY.
  3. LOCATION OF THE PROPOSED SEWER PIPE RELATIVE TO EXISTING SERVICES HAS YET TO BE CONFIRMED. ALL DESIGN DETAILS INCLUDING LOCATION, LEVEL AND LENGTH OF PIPE IS SUBJECT TO CONFIRMATION OF LOCATION AND LEVEL OF EXISTING SURFACES AND SERVICES.

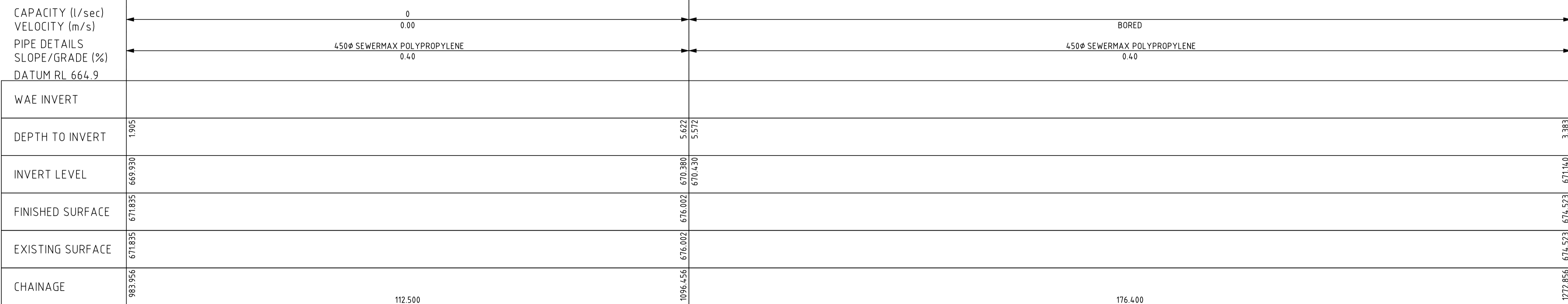

DRAINAGE LONGITUDINAL SECTION FOR LINE 1  
 SCALES: HORIZONTAL 1:500 VERTICAL 1:100

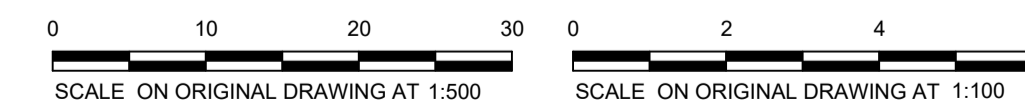

VER	BY	AMENDMENTS	DATE
A	T.H.	ISSUED FOR INFORMATION	5-11-2021
B	T.H.	PIPE SIZES INCREASED TO 450mm	02-02-2022
C			
D			
E			
F			
G			

• THE POSITION OF SERVICES SHOWN ON THIS DRAWING ARE INDICATIVE ONLY AND HAVE BEEN PLOTTED FROM PLANS AND DRAWINGS SUPPLIED BY RELEVANT AUTHORITIES.  
 • SERVICE AUTHORITY FITS, MANHOLES, POLES, MARKER POSTS, ETC., WHERE SIGHTED AT TIME OF SURVEY, HAVE BEEN LOCATED. THE SURVEY DOES NOT INCLUDE INVESTIGATION OR LOCATION OF UNDERGROUND INFRASTRUCTURE.  
 • SERVICES INFORMATION SHOWN ON THIS DRAWING HAS BEEN OBTAINED THROUGH A DIAL BEFORE YOU DIG SEARCH AND IS VALID FOR THE PERIOD OF TIME FROM THE DATE OF ISSUE NOMINATED BY THE AUTHORITY.  
 • PRIOR TO ANY DEMOLITION, EXCAVATION OR CONSTRUCTION ON OR ADJACENT TO THE SITE IT IS THE RESPONSIBILITY OF THE DEVELOPER AND CONTRACTORS TO APPLY FOR AND OBTAIN UP TO DATE PLANS THROUGH A NEW DIAL BEFORE YOU DIG SEARCH AND TO CONTACT ALL THE RELEVANT AUTHORITIES TO ESTABLISH AND CONFIRM THE DETAILED LOCATION AND DEPTH OF ALL UNDERGROUND SERVICES.

CLIENT:  
 PRIME MOSS VALE

**BW**  
 Beveridge Williams  
 Land Development Consultants  
 Registered Surveyors  
 www.beveridgewilliams.com.au

DETAILS:  
 PLAN OF STAGE 2 TRUNK SEWER WORKS  
 ASSOCIATED WITH CHELSEA GARDENS  
 DEVELOPMENT, YARRAWA ROAD  
 MOSS VALE

SCALE ORIGINAL SHEET SIZE  
 1:500 A1  
 CAD REFERENCE: lidar

SURVEYOR: X.X.  
 DRAWN: X.X.  
 CHECKED: D.S.  
 SURVEY DATE: X.X.X  
 VERTICAL DATUM: AHD  
 HORIZONTAL DATUM: MGA

PROJECT No.  
 18001S3  
 DRAWING REF.  
 SECTION 983.956-1272.856  
 VERSION B  
 SHEET 11 OF 14

53114

53115

53116

53117

NOTES:

1. THIS PLAN AND LONGITUDINAL SECTION HAS BEEN PREPARED USING LEVELS INTERPOLATED FROM LIDAR DATA AND LOCATION OF SERVICES AS PROVIDED BY WINGECARRIBEE SHIRE COUNCIL AND/OR DIAL BEFORE YOU DIG INFORMATION ONLY AND IS FOR PLANNING PURPOSES ONLY.
2. ALL LEVELS AND PIPE GRADES ARE SUBJECT TO CONFIRMATION OF LEVELS BY SURVEY.
3. LOCATION OF THE PROPOSED SEWER PIPE RELATIVE TO EXISTING SERVICES HAS YET TO BE CONFIRMED. ALL DESIGN DETAILS INCLUDING LOCATION, LEVEL AND LENGTH OF PIPE IS SUBJECT TO CONFIRMATION OF LOCATION AND LEVEL OF EXISTING SURFACES AND SERVICES.

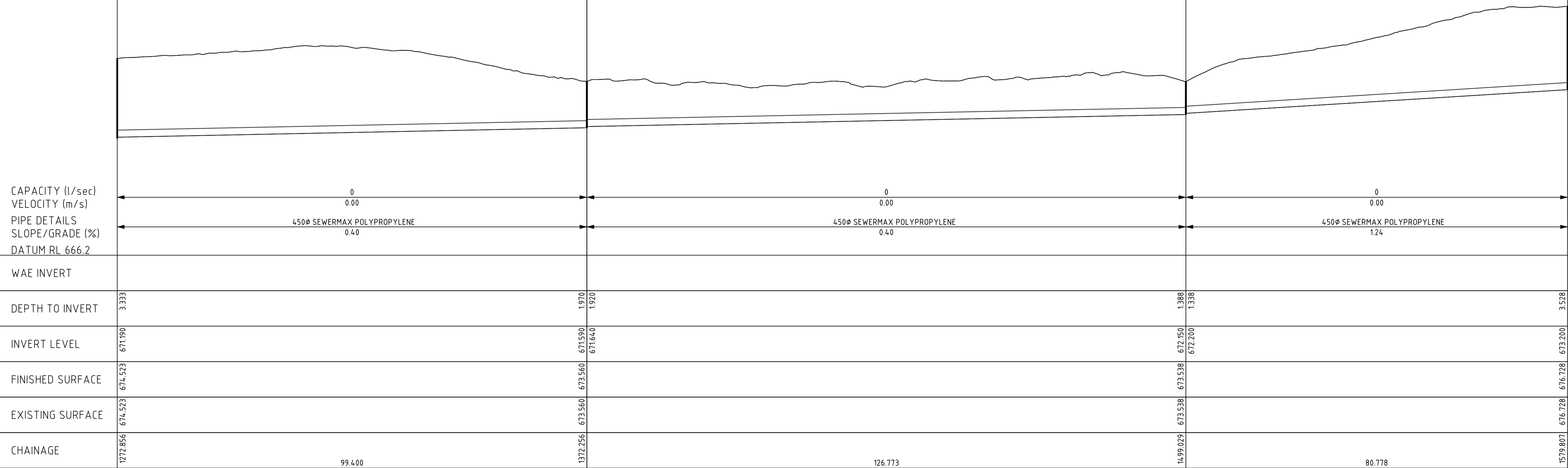

DRAINAGE LONGITUDINAL SECTION FOR LINE 1  
 SCALES: HORIZONTAL 1:500 VERTICAL 1:100

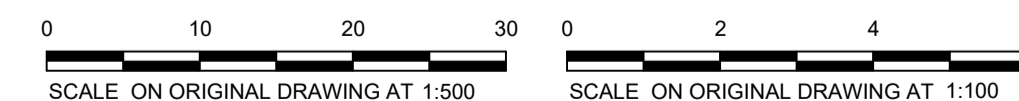

VER	BY	AMENDMENTS	DATE
A	T.H.	ISSUED FOR INFORMATION	5-11-2021
B	T.H.	PIPE SIZES INCREASED TO 450mm	02-02-2022
C			
D			
E			
F			
G			

• THE POSITION OF SERVICES SHOWN ON THIS DRAWING ARE INDICATIVE ONLY AND HAVE BEEN PLOTTED FROM PLANS AND DRAWINGS SUPPLIED BY RELEVANT AUTHORITIES.  
 • SERVICE AUTHORITY FITS, MANHOLES, POLES, MARKER POSTS, ETC., WHERE SIGHTED AT TIME OF SURVEY, HAVE BEEN LOCATED. THE SURVEY DOES NOT INCLUDE INVESTIGATION OR LOCATION OF UNDERGROUND INFRASTRUCTURE.  
 • SERVICES INFORMATION SHOWN ON THIS DRAWING HAS BEEN OBTAINED THROUGH A DIAL BEFORE YOU DIG SEARCH AND IS VALID FOR THE PERIOD OF TIME FROM THE DATE OF ISSUE NOMINATED BY THE AUTHORITY.  
 • PRIOR TO ANY DEMOLITION, EXCAVATION OR CONSTRUCTION ON OR ADJACENT TO THE SITE IT IS THE RESPONSIBILITY OF THE DEVELOPER AND CONTRACTORS TO APPLY FOR AND OBTAIN UP TO DATE PLANS THROUGH A NEW DIAL BEFORE YOU DIG SEARCH AND TO CONTACT ALL THE RELEVANT AUTHORITIES TO ESTABLISH AND CONFIRM THE DETAILED LOCATION AND DEPTH OF ALL UNDERGROUND SERVICES.



CLIENT:  
 PRIME MOSS VALE

**BW**  
 Beveridge Williams  
 Land Development Consultants  
 Registered Surveyors  
 www.beveridgewilliams.com.au

DETAILS:  
 PLAN OF STAGE 2 TRUNK SEWER WORKS  
 ASSOCIATED WITH CHELSEA GARDENS  
 DEVELOPMENT, YARRAWA ROAD  
 MOSS VALE

ORIGINAL SCALE 1:500 SHEET SIZE A1  
 CAD REFERENCE: lidar

SURVEYOR: X.X.  
 DRAWN: X.X.  
 CHECKED: D.S.  
 SURVEY DATE: X.X.X  
 VERTICAL DATUM: AHD  
 HORIZONTAL DATUM: MGA

PROJECT No. 18001S3  
 DRAWING REF. SECTION 1272.856-1579.807  
 VERSION B  
 SHEET 12 OF 14

53117

53118

53119

53120

53121

53122

NOTES:

1. THIS PLAN AND LONGITUDINAL SECTION HAS BEEN PREPARED USING LEVELS INTERPOLATED FROM LIDAR DATA AND LOCATION OF SERVICES AS PROVIDED BY WINGECARRIBEE SHIRE COUNCIL AND/OR DIAL BEFORE YOU DIG INFORMATION ONLY AND IS FOR PLANNING PURPOSES ONLY.
2. ALL LEVELS AND PIPE GRADES ARE SUBJECT TO CONFIRMATION OF LEVELS BY SURVEY.
3. LOCATION OF THE PROPOSED SEWER PIPE RELATIVE TO EXISTING SERVICES HAS YET TO BE CONFIRMED. ALL DESIGN DETAILS INCLUDING LOCATION, LEVEL AND LENGTH OF PIPE IS SUBJECT TO CONFIRMATION OF LOCATION AND LEVEL OF EXISTING SURFACES AND SERVICES.

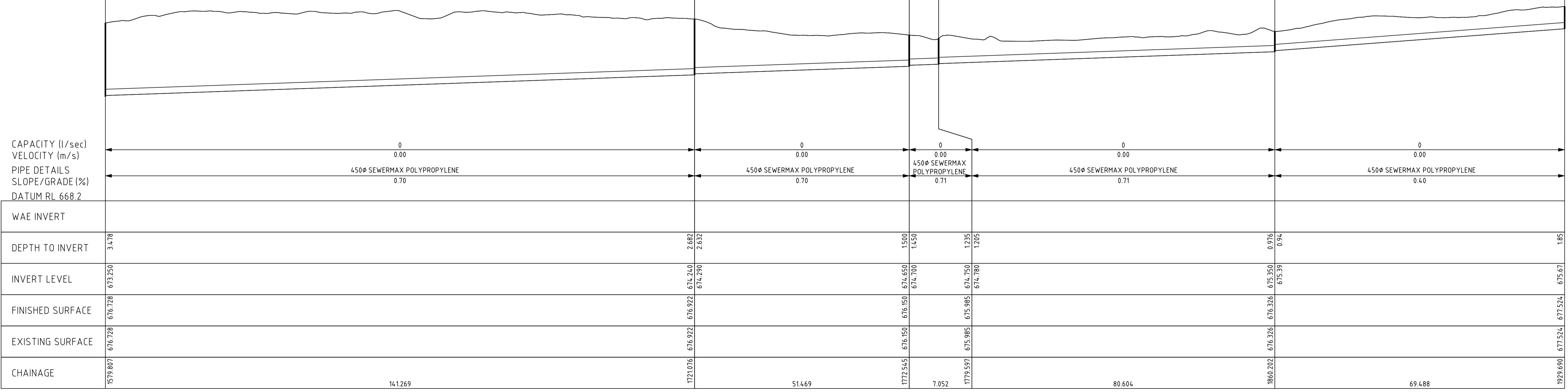

DRAINAGE LONGITUNDINAL SECTION FOR LINE 1  
 SCALES: HORIZONTAL 1:500 VERTICAL 1:100

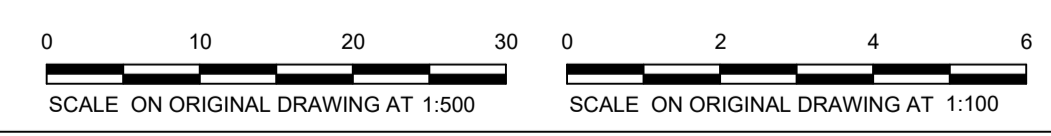

VER	BY	AMENDMENTS	DATE
A	T.H.	ISSUED FOR INFORMATION	5-11-2021
B	T.H.	PIPE SIZES INCREASED TO 450mm	02-02-2022
C			
D			
E			
F			
G			

• THE POSITION OF SERVICES SHOWN ON THIS DRAWING ARE INDICATIVE ONLY AND HAVE BEEN PLOTTED FROM PLANS AND DRAWINGS SUPPLIED BY RELEVANT AUTHORITIES.  
 • SERVICE AUTHORITY FITS, MANHOLES, POLES, MARKER POSTS, ETC., WHERE SIGHTED AT TIME OF SURVEY, HAVE BEEN LOCATED. THE SURVEY DOES NOT INCLUDE INVESTIGATION OR LOCATION OF UNDERGROUND INFRASTRUCTURE.  
 • SERVICES INFORMATION SHOWN ON THIS DRAWING HAS BEEN OBTAINED THROUGH A DIAL BEFORE YOU DIG SEARCH AND IS VALID FOR THE PERIOD OF TIME FROM THE DATE OF ISSUE NOMINATED BY THE AUTHORITY.  
 • PRIOR TO ANY DEMOLITION, EXCAVATION OR CONSTRUCTION ON OR ADJACENT TO THE SITE IT IS THE RESPONSIBILITY OF THE DEVELOPER AND CONTRACTORS TO APPLY FOR AND OBTAIN UP TO DATE PLANS THROUGH A NEW DIAL BEFORE YOU DIG SEARCH AND TO CONTACT ALL THE RELEVANT AUTHORITIES TO ESTABLISH AND CONFIRM THE DETAILED LOCATION AND DEPTH OF ALL UNDERGROUND SERVICES.

CLIENT:  
 PRIME MOSS VALE

**BW** Beveridge Williams  
 Land Development Consultants  
 Registered Surveyors  
 www.beveridgewilliams.com.au

DETAILS:  
 PLAN OF STAGE 2 TRUNK SEWER WORKS  
 ASSOCIATED WITH CHELSEA GARDENS  
 DEVELOPMENT, YARRAWA ROAD  
 MOSS VALE

ORIGINAL SHEET SIZE A1  
 SCALE 1:500  
 CAD REFERENCE: lidar

SURVEYOR: X.X.  
 DRAWN: X.X.  
 CHECKED: D.S.  
 SURVEY DATE: X.X.X  
 VERTICAL DATUM: AHD  
 HORIZONTAL DATUM: MGA

PROJECT No. 18001S3  
 DRAWING REF. SECTION 1579.807-1929.690  
 VERSION A  
 SHEET 13 OF 14

3122

3123

3124

3125

- NOTES:
1. THIS PLAN AND LONGITUDINAL SECTION HAS BEEN PREPARED USING LEVELS INTERPOLATED FROM LIDAR DATA AND LOCATION OF SERVICES AS PROVIDED BY WINGECARRIBEE SHIRE COUNCIL AND/OR DIAL BEFORE YOU DIG INFORMATION ONLY AND IS FOR PLANNING PURPOSES ONLY.
  2. ALL LEVELS AND PIPE GRADES ARE SUBJECT TO CONFIRMATION OF LEVELS BY SURVEY.
  3. LOCATION OF THE PROPOSED SEWER PIPE RELATIVE TO EXISTING SERVICES HAS YET TO BE CONFIRMED. ALL DESIGN DETAILS INCLUDING LOCATION, LEVEL AND LENGTH OF PIPE IS SUBJECT TO CONFIRMATION OF LOCATION AND LEVEL OF EXISTING SURFACES AND SERVICES.



DRAINAGE LONGITUDINAL SECTION FOR LINE 1  
 SCALES: HORIZONTAL 1:500 VERTICAL 1:100

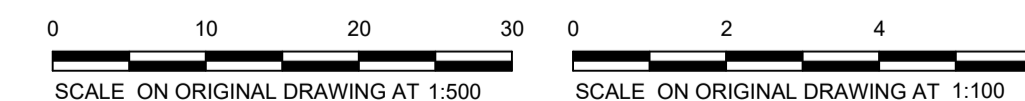

VER	BY	AMENDMENTS	DATE
A	T.H.	ISSUED FOR INFORMATION	5-11-2021
B	T.H.	PIPE SIZES INCREASED TO 450mm	02-02-2022
C			
D			
E			
F			
G			

• THE POSITION OF SERVICES SHOWN ON THIS DRAWING ARE INDICATIVE ONLY AND HAVE BEEN PLOTTED FROM PLANS AND DRAWINGS SUPPLIED BY RELEVANT AUTHORITIES.  
 • SERVICE AUTHORITY FITS, MANHOLES, POLES, MARKER POSTS, ETC., WHERE SIGHTED AT TIME OF SURVEY, HAVE BEEN LOCATED. THE SURVEY DOES NOT INCLUDE INVESTIGATION OR LOCATION OF UNDERGROUND INFRASTRUCTURE.  
 • SERVICES INFORMATION SHOWN ON THIS DRAWING HAS BEEN OBTAINED THROUGH A DIAL BEFORE YOU DIG SEARCH AND IS VALID FOR THE PERIOD OF TIME FROM THE DATE OF ISSUE NOMINATED BY THE AUTHORITY.  
 • PRIOR TO ANY DEMOLITION, EXCAVATION OR CONSTRUCTION ON OR ADJACENT TO THE SITE IT IS THE RESPONSIBILITY OF THE DEVELOPER AND CONTRACTORS TO APPLY FOR AND OBTAIN UP TO DATE PLANS THROUGH A NEW DIAL BEFORE YOU DIG SEARCH AND TO CONTACT ALL THE RELEVANT AUTHORITIES TO ESTABLISH AND CONFIRM THE DETAILED LOCATION AND DEPTH OF ALL UNDERGROUND SERVICES.



CLIENT:  
PRIME MOSS VALE

**Beveridge Williams**  
 Land Development Consultants  
 Registered Surveyors  
[www.beveridgewilliams.com.au](http://www.beveridgewilliams.com.au)

DETAILS:  
**PLAN OF STAGE 2 TRUNK SEWER WORKS**  
 ASSOCIATED WITH CHELSEA GARDENS  
 DEVELOPMENT, YARRAWA ROAD  
 MOSS VALE

ORIGINAL SHEET SIZE A1  
 SCALE 1:500  
 CAD REFERENCE: lidar

SURVEYOR: X.X.  
 DRAWN: X.X.  
 CHECKED: D.S.  
 SURVEY DATE: X.X.X  
 VERTICAL DATUM: AHD  
 HORIZONTAL DATUM: MGA

PROJECT No. 18001S3  
 DRAWING REF. SECTION 1929.690-2165.737  
 VERSION A  
 SHEET 14 OF 14